

Type I

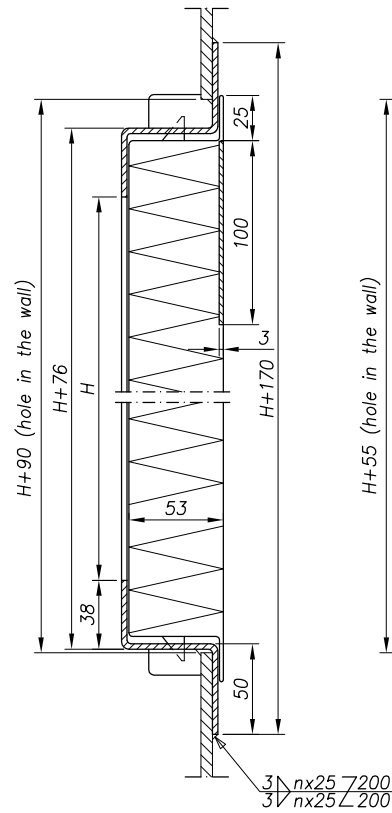

Type II

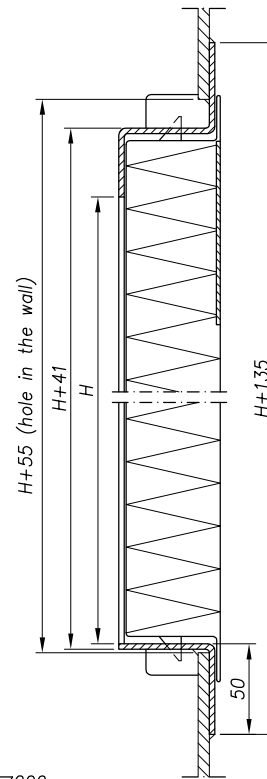

Type III

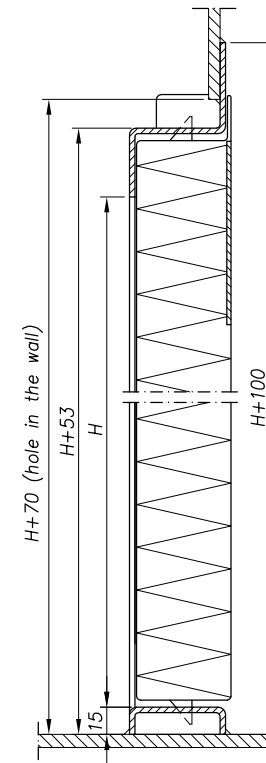

Door-frame type A
(screwed)

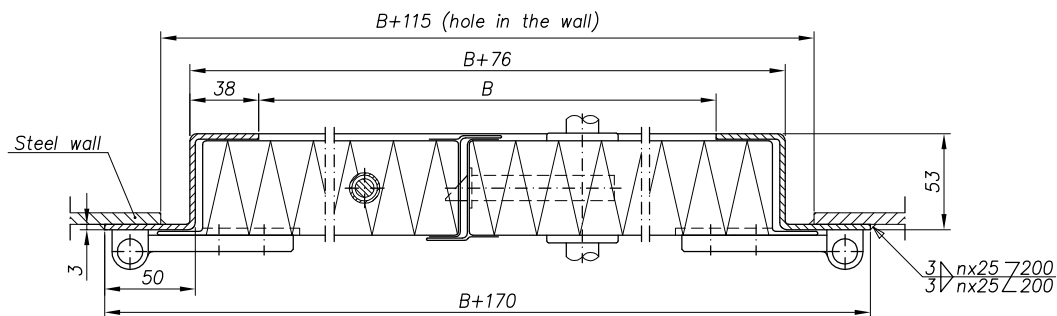
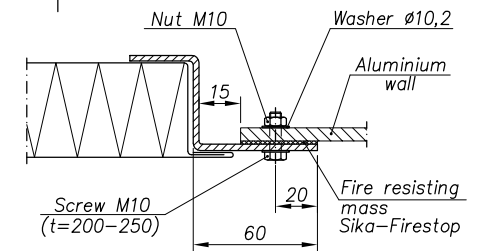

H	B
1800	1200
1850	1400
1900	1500
1950	1600
2000	2000



LUBMOR Sp. z o.o.

ul. Wieleńska 1, 64-980 Trzcianka
tel. +48/67/216-22-44
fax +48/67/210-19-19
e-mail: lubmor@lubmor.pl
www.lubmor.pl

DOUBLE DOOR CLASS A0-A60

KK 24-14
34-865

DOUBLE DOOR CLASS A0-A60

APPROPRIATION

Double door class A0-A60 is designed for closing the passageways in fire proof divisions, engine casings and stair closures of required fire protection A0-A60 inside all float and land objects.
The door to be welded or screwed to the bulkhead class A.

EXECUTION

Specially profiled door – frame is made of 3 mm cold rolled stress free steel plate. The door – leaves are made of two cassettes of steel sheet as a box construction. The inside and outside cassettes form a closed space which is insulated of mineral wool. Inside door – leaf has also a steel frame made of channel profile. Mineral wool ensures thermal insulation of the door – leaf.

Design of the door – leaves allows to make it in varieties as below :

- painted of stove enamels (M),
- covered of PVC foiled galvanized steel sheet (D).

Active door-leaf is equipment with mortise lock and upper bolt, which ensures additional fixing of the door-leaf to the door-frame. Blocked door-leaf is equipment with both ways bolt. Stiffening top part of the door – leaf with 3mm steel plate allow to mount a self – closing devices and an electromagnetic door holders. The door can be made with the pass for fire hose of dimensions 150x150 mm. The door in the pass is hanged on stainless steel spring hinge. The door can be equipped with window together with glasses class A60. Maximum dimensions of the windows are 600mm x 400mm or Ø400mm.

DELIVERY RANG

Delivery rang includes the doors without self – closing devices, electromagnetic door holders, patent cylinders, fixing elements for screwing and fire resisting mass.

PACKING, TRANSPORT, STORAGE

The doors are protected against mechanical damages and can be transported in containers. The goods are placed on the pallets with wooden separators, can be displaced by means of the cranes and fork – lift trucks. They must be stored in roofed accommodations.

DIVISION, MARKING AND FINISHING

Kinds of the doors :

- class A0
- class A15
- class A30
- class A60

Varieties :

- P - right-hand door (acc. to drawing)
- L - left-hand door (as reflected)

Types (dependable on the sill) :

- I - door with high sill - bottom of door – leaf with back part
- II - door with lower sill - bottom of door – leaf with back part
- III - door without sill - bottom of door – leaf without back part

Kinds of the door – leaves (dependable on door – leaf finishing) :

- M - z/p - door – leaves painted acc. to RAL catalogue
- D - z/p - door – leaves covered with decorative plate of PVC foil acc. to DOBEL or GISLAVED catalogue
 - z - colour from hinge side
 - p - colour from the other side

Kinds of the door – frames :

- Z - welded to the bulkhead class A - primed
- A - screwed to the bulkhead class A – painted acc. to RAL catalogue

Equipment :

- door with full lock plate (without marking)
- Wp - door with lock plate suitable for cylinder
- Pw - door with pass for fire hose
- O - door with rectangular window
- B - door with porthole

EXAMPLE OF DESIGNATION

Double door class A60 clear opening HxB – 1800x800, right – hand variety (**P**), with door plate suitable for cylinder (**Wp**), with pass for fire hose (**Pw**), with screwed door – frame and painted RAL 8004 (**A/8004**), door with high sill (**I**), door-leaves covered of PVC foil (**D**), from hinges side (**z**) colour 1205, from the other side (**p**) colour 1340. Door with porthole(**B**) Ø400mm.

DOUBLE DOOR CLASS A60 1800x800-P-Wp-Pw-A/8004-B/400-I-D z1205/p1340 acc. to catalogue card no **KK24-14/34-865**.

This catalogue card corresponds with drawing no N24-09/34-865.